

INFLUENCE OF FOREIGN MATERIALS UPON THE THERMAL DECOMPOSITION OF DOLOMITE, CALCITE AND MAGNESITE PART II. INFLUENCE OF THE PRESENCE OF WATER

J. PAULIK and F. PAULIK

Institute for General and Analytical Chemistry, Technical University, Budapest (Hungary)

K. WIECZOREK-CIUROWA

Institute of Inorganic Chemistry and Technology, Technical University of Cracow, Cracow (Poland)

(Received 14 September 1979)

ABSTRACT

The influence of water vapour on the course of the thermal decompositions of pure calcite, magnesite and dolomite, and of these materials mixed with 2% sodium chloride, was studied partly under dynamic, and partly under quasi-isothermal heating conditions. The sample holders used were of four different types, i.e. the carbon dioxide in direct contact with the solid phase of the sample was at different partial pressures. The investigations were carried out in the presence of dried air as well as in air of 60% and 100% humidity content. It is stated that the presence of water vapour increases the decomposition temperature of the first stage of dolomite decomposition (by about 20–50°C) but reduces it in the second stage (by about 5–10°C), as it does in the decomposition of calcite and magnesite. It was also found that the presence of sodium chloride and water vapour together reduces the temperature of both decomposition stages of dolomite.

INTRODUCTION

In Part I of this series [1] one problem remained unanswered. On investigating the decomposition of dolomite under various experimental conditions, it was observed that in certain cases (Fig. 4, curves 3, 5, 7 and 6, and Fig. 3, curves 3, 5, 7, and 4, 6, 8 in ref. 1) the process took place in an irregular manner. We suspected that the phenomena were caused by the presence of water vapour in the ambient atmosphere.

It has been the general consensus of opinion [2–9] that the decomposition of dolomite, calcite and magnesite is promoted by water vapour. However, the size of this effect and its dependence on the experimental conditions remain unexplored. Since some of our observations were in direct contradiction to the general view mentioned above, we decided to study this problem more thoroughly. Our results are set out and discussed below.

METHOD AND EXPERIMENTAL CONDITIONS

The experiments were conducted using a Q-derivatograph (Hungarian Optical Works, Budapest) and the operation method was modified [10–13]

to suit the present purpose. The apparatus was equipped with an adapter (Fig. 1) suitable for establishing a controlled gas atmosphere around the sample. There was a metered flow of gases through the adapter, and the entry of outside air was prevented. This made possible the use of corrosive gases (an example will be given Part III of the present series [14]). There was a circular space between the diaphragm disc (5) and the corundum bell-cover (7), in which the outgoing gas accelerated to such an extent that any back-flow of air was prevented. There was another gap in the centre of the furnace stand (8), the purpose of which was to prevent the outflow of the gas used by sucking in a certain amount of air. The gas flow around the upper diaphragm disc (4) was upwards only. This gas, together with the gases liberated from the sample, left the bell-cover via tube 18. This gas was required for thermo-gas-titrimetric examination [10,11]. The outflow of gases through tube 17 had to be twice as large and the outflow through tube 18 half as large as the inflow through tube 6. It should be pointed out at this stage that for safety reasons pure hydrogen must not be used because an explosive mixture might be formed with air in the lower part of the bell-cover. It should, however, be possible to use a hydrogen and nitrogen mixture with the ratio $H_2/N_2 < 0.1$. In this case, it is also necessary to introduce nitrogen at point 20 to prevent any air entering the bell-cover.

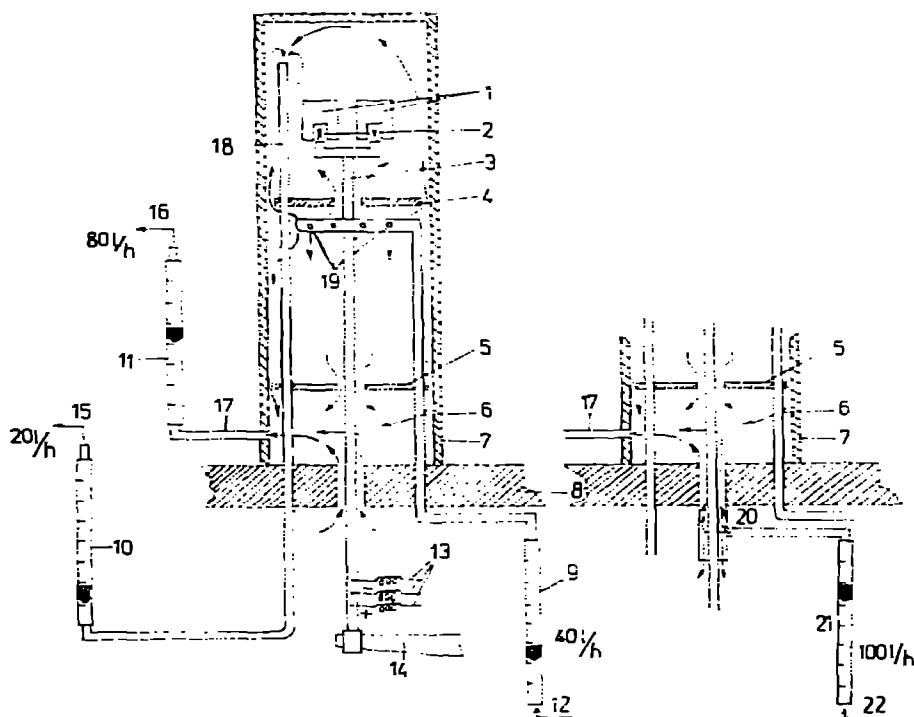

Fig. 1. Adapter for controlled gas atmosphere. 1, Sample holders; 2, thermoelements; 3, corundum tube with borings; 4 and 5, corundum diaphragm plates; 6 and 20, gas inlet tube; 7, corundum bell cover; 8, furnace stand; 9, 10, 11 and 21, rotameters; 12 and 22, gas inlet; 13, flexible conductors joining the thermoelements; 14, balance arm; 15 and 16, gas exhaust; 17 and 18, tube for gas outlet; 19, gas inlet.

The influence of water vapour upon the decomposition of dolomite was examined in the following way.

First, without applying a heating program, the decomposition temperature of dolomite was approached; thereafter the temperature of the sample was raised at a constant, very slow rate ($0.2^{\circ}\text{C min}^{-1}$). In the first experiment (curves 1 and 2, Fig. 2), the air passing through the adapter was saturated with water vapour at room temperature, while its relative humidity in the second experiment (curves 3 and 4) was 60%. In the third experiment, dry air was used (curves 5 and 6). Air was saturated with water vapour by passing the air through a wash-bottle filled with water. Drying was carried out by passing the air over phosphorus pentoxide. Both the TG and DTA curves were obtained under the experimental conditions described above and an open crucible was used to hold the sample.

The influence of water vapour upon the decomposition of dolomite, calcite and magnesite was also examined under isothermal conditions. The dolomite and calcite samples and magnesite sample were heated up to 710 and 550°C , respectively, and then the temperature was kept constant. Dry air and air saturated with water vapour were alternately passed through the gas adapter for 30–50 min periods. The sample was kept in an open crucible. The weight changes of the sample were recorded. The TG and DTG curves shown in Fig. 3 were obtained.

In order to study the joint influence of water vapour, CO_2 , and NaCl upon the decomposition of dolomite, we repeated an earlier experiment (Figs. 3 and 4, ref. 1) in a somewhat modified way. Two heating techniques were used: quasi-isothermal (Fig. 4) and dynamic (Fig. 5), and four different sample holders were employed: polyplate (curves 1, 2, 8 and 9), open crucible (curves 3, 4, 10 and 11), covered crucible (curves 5, 6, 12 and 13), and labyrinth crucible (curves 7 and 14). The samples consisted of pure dolomite (curves 1–7), and dolomite with 2% NaCl (curves 8–14), and the experiments were carried out both in dry air (curves 2, 4, 6, 7, 9, 11, 13 and 14)

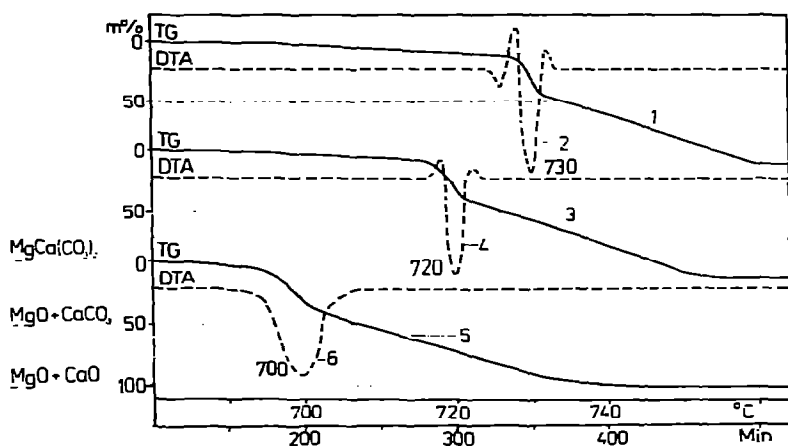

Fig. 2. TG and DTA curves for dolomite. Heating technique: dynamic ($0.2^{\circ}\text{C min}^{-1}$). Sample holder: open crucible. Atmosphere: air saturated with water at 20°C (curves 1 and 2; air of 60% humidity (curves 3 and 4); dried air (curves 5 and 6).

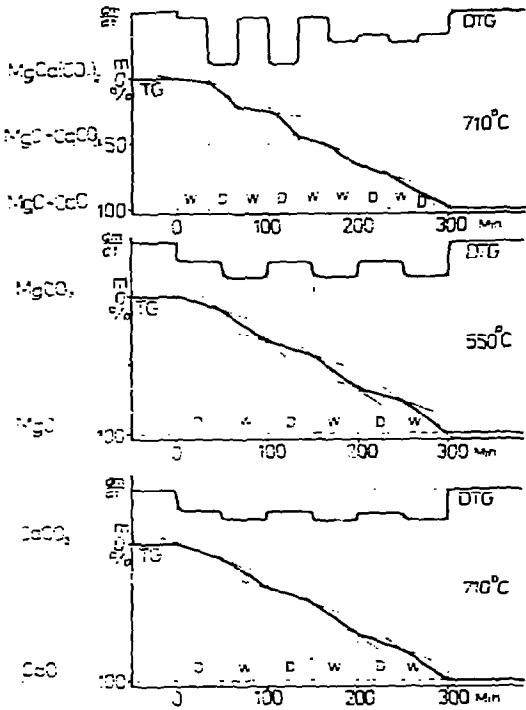

Fig. 3. TG and DTG curves for dolomite, magnesite and calcite. Heating technique: isothermal. Sample holder: open crucible. Atmosphere: W = air containing 100% humidity at 20°C; D = dried air.

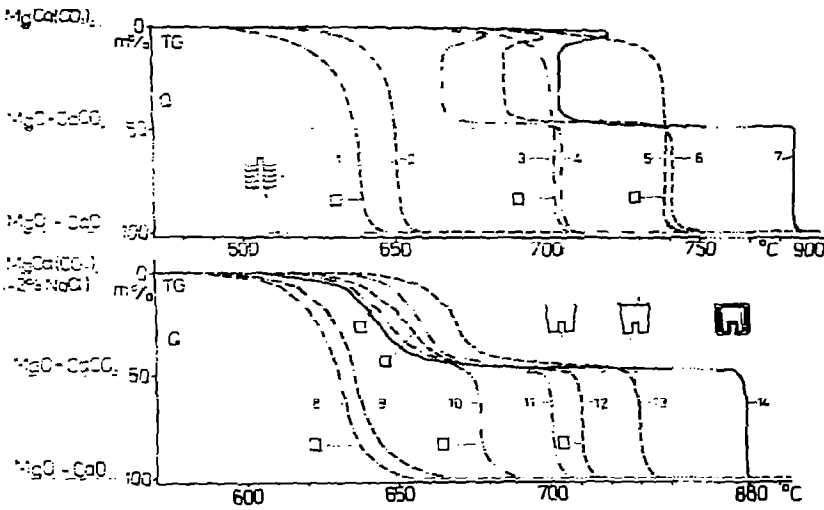

Fig. 4. TG curves for dolomite. Heating technique: quasi-isothermal. Sample holders: polyplate (curves 1, 2, 8 and 9); open crucible (curves 3, 4, 10 and 11); covered crucible (curves 5, 6, 12 and 13); labyrinth (curves 7 and 14). Atmosphere: air containing 100% humidity at 20°C, □ (curves 1, 3, 5, 8, 10 and 12); dried air (curves 2, 4, 6, 7, 9, 11, 13 and 14). Sample: pure dolomite (curves 1–7); dolomite mixed with 2% NaCl (curves 8–14).

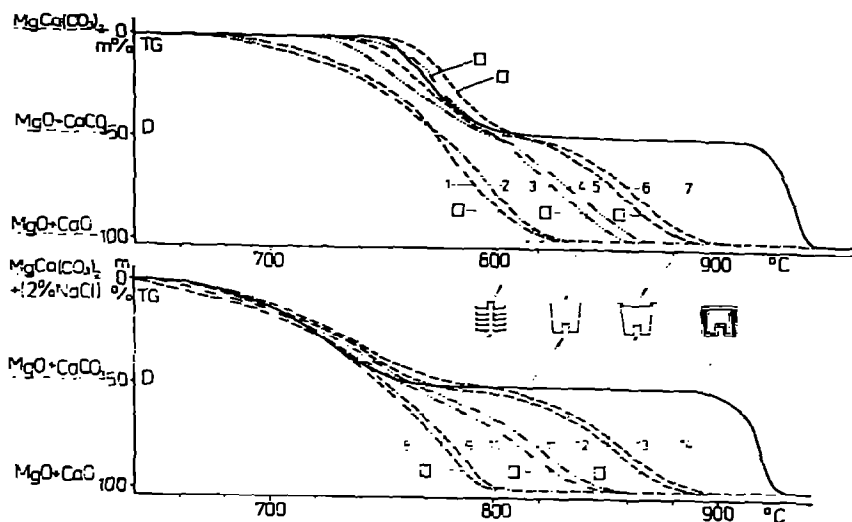

Fig. 5. TG curves for dolomite. Heating technique: dynamic ($10^{\circ}\text{C min}^{-1}$). Sample holders: polyplate (curves 1, 2, 8 and 9); open crucible (curves, 3, 4, 10 and 11); covered crucible (curves 5, 6, 12 and 13); labyrinth (curves 7 and 14). Atmospheres: air containing 100% humidity at 20°C , \square (curves 1, 3, 5, 8, 10 and 12); dried air (curves 2, 4, 6, 7, 9, 11, 13 and 14). Sample: pure dolomite (curves 1–7); dolomite mixed with 2% NaCl (curves 8–14).

and in an air stream saturated with water vapour (curves 1, 3, 5, 8, 10 and 12) at room temperature.

RESULTS AND DISCUSSION

Even on the basis of exploratory investigations, we were able to make an important observation. The TG and DTA curves of Fig. 2 unambiguously proved that the water vapour present in the gas atmosphere — in contrast to the earlier general opinion — does not promote, but in fact hinders, the first stage of the decomposition of dolomite. By applying a very slow, quasi-dynamic heating program we observed that a reduction of the relative humidity of the air in contact with the sample from 100% (curves 1 and 2) to 60% (curves 3 and 4) and later to 0% (curves 5 and 6) caused a lowering of the decomposition temperature from 730 to 720°C and then to 700°C . In fact, in all three cases the decomposition started slowly, at significantly lower temperatures, but accelerated markedly only at the apparent decomposition temperatures. This is evident from the TG curves and is confirmed by the DTA curves.

The TG and DTG curves in Fig. 3 are in good agreement with the above observations. These curves were recorded for the decomposition of dolomite, magnesite and calcite under isothermal conditions in dry (D) and moist (W) air. The slopes of successive sections of the TG curves and the amplitudes of the corresponding “steps” on the DTG curves conclusively prove that during the first stage of the decomposition of dolomite water vapour slows down

the process, while during the second stage it promotes the reaction. At the same time, and this is in accordance with the earlier general opinion, the decomposition of magnesite and calcite are accelerated by the presence of water vapour.

Figs. 4 and 5 illustrate the influence of water vapour, carbon dioxide, sodium chloride and the type of heating technique upon the decomposition of dolomite. Of the large amount of information contained in the curves, only the most important points will be discussed.

The difference between curves 3 and 4 and 5 and 6 in Fig. 4 clearly shows that water vapour inhibits the first, while it accelerates the second stage of the decomposition of dolomite.

Curves 4, 6 and 7 in Fig. 4 show that nucleus formation in a dry gas atmosphere and under the conditions of the quasi-isothermal heating technique could only start with difficulty. In all three cases the sample first became overheated. After the formation of a sufficient number of nuclei the decomposition could begin to proceed unhindered at the preselected very slow and constant rate, the sample temperature spontaneously dropped by 15–20°C and then became stabilized.

As has already been shown in Part I [1], sodium chloride alone promotes both the decomposition stages of dolomite. Curves 8–13 in Figs. 4 and 5 clearly demonstrate that the presence of water vapour enhances this effect.

A similar influence is exerted by water vapour and sodium chloride together upon the decomposition of kaolinite. The phenomenon was explained by Szabó et al. [16] in terms of the formation of trace amounts of chlorhydric acid. This may serve as a basis for a further study of the mechanism of the above effects.

By investigating the thermal decomposition under various experimental conditions, we observed earlier [1,15] [Fig. 4 (curves 4, 6 and 8) ref. 1] that the first stage of decomposition took place in the labyrinth crucible (in pure carbon dioxide atmosphere) at a lower temperature than in the open and covered crucibles (i.e. in atmospheres which contained only about 3 and 13 vol.% carbon dioxide, respectively). However, the phenomenon becomes understandable if we bear in mind that on the one hand, not only the presence of carbon dioxide but also that of water vapour can raise the decomposition temperature, and on the other, in the sequence of crucibles (open, covered and labyrinth), the concentration of carbon dioxide was increasing, while that of water vapour was decreasing.

In the case of the labyrinth crucible, at the start of decomposition the stream of the evolving carbon dioxide not only carried away the water vapour which had been present originally inside the crucible, but simultaneously kept away the external moist atmosphere. However, with the other crucibles (covered and open) the water vapour present in the air could have access to the sample (particularly in the case of the open crucible), despite an overall flow of carbon dioxide away from the sample. The presence of water vapour together with the carbon dioxide shifted the decomposition of the dolomite towards higher temperatures than carbon dioxide alone. This situation may also explain the irregular sequence of the curves in Figs. 3 and 4 in ref. 1 and Figs. 4 and 5 in the present study.

The appearance of curve 6 in Fig. 4 of ref. 1 was even more enigmatic. In this case — for no obvious reason — the temperature of the sample appeared to oscillate with an amplitude of about 40°C. The explanation of this phenomenon is more complicated, since it is a result of a combination of several effects. However, it should be noted that this phenomenon is important above all from the methodological point of view.

Curves 5 and 6 of Fig. 4 were obtained under quasi-isothermal heating conditions by using a covered crucible. The partial pressure of carbon dioxide was about 100 Torr. When the atmosphere was saturated with water vapour at room temperature, the decomposition took place at 735°C, while in dry gases it occurred at 680°C. This also demonstrates that the decomposition temperature is determined by both the concentration of carbon dioxide and water vapour when present together. Should the concentration of either of these two components change at any time, this would also cause changes in the decomposition rate. However, it is in the nature of the quasi-isothermal heating technique that the reaction takes place only at a constant rate selected in advance. Thus the system responds to every spontaneous change in the rate of weight change by immediately adjusting the temperature of the sample, up or down as necessary. Over the first part of curve 6 in Fig. 4 of ref. 1 the 40°C temperature oscillations indicate that there were also fluctuations in the composition of the gases during the same period. (Under dynamic conditions this difference was less, see Fig. 2.)

Under the usual working conditions, there is a continuous exchange of gases between the inside of the crucible and its surroundings due to the fact that the crucible cover does not fit tightly. Air mixed with the gaseous decomposition products streams outwards from the crucible, while moist air flows into the crucible. When the quasi-isothermal technique is used, uniform evolution of gaseous decomposition products is ensured, the composition of the gas within the crucible becomes constant and the temperature of the sample becomes stabilized (curves 3—6, Fig. 1 of ref. 1).

Accordingly, we are entitled to suppose that under the experimental conditions of curve 6 in Fig. 4 of ref. 1, and only under these conditions, an instability appeared in the opposing gas currents, and gas mixtures with alternately high and low carbon dioxide and water vapour concentrations were formed periodically. Due to the inertia of the heating programmer system, this fluctuation could be compensated only with a certain delay. The result of this was that the sample temperature oscillated about an average value rather like a balance oscillates about the equilibrium position.

It has been demonstrated in Part I [1] and the present study that experimental conditions can considerably influence the decomposition, in a manner which could not be foreseen and which can be extremely complicated. The presence or absence of sodium chloride and water, the heating technique, and the partial pressure of the decomposition products can all influence the kinetics of thermal dissociation of calcium and magnesium carbonates. The observed effects are most probably caused by the formation of different solid phases with different physico-chemical properties, e.g. porosity, pore size, etc. Part III [14] of the series is concerned with an attempt to assess the reactivity of the calcination products of calcite, magnesite and dolomite, obtained under different conditions, towards sulphur dioxide.

ACKNOWLEDGEMENTS

The authors wish to thank Professors E. Pungor and E.M. Bulewicz for valuable discussions, and would like to acknowledge the technical assistance of Mrs. M. Kiss and Miss I. Fábíán.

REFERENCES

- 1 K. Wieczorek-Ciurowa, J. Paulik and F. Paulik, *Thermochim. Acta*, 38 (1980) 157.
- 2 P.L. Robinson, H.C. Smith and H.V.A. Briscoe, *J. Chem. Soc.*, (1926) 836.
- 3 G.F. Hüttig and H. Heinz, *Z. Anorg. Chem.*, 255 (1948) 223.
- 4 Y. Schwob, *Rev. Mater. Constr. Trav. Publics*, (1949) 409.
- 5 F. Bischoff, *Z. Anorg. Chem.*, 262 (1950) 288.
- 6 J. Takauaka and S. Yajima, *J. Sci. Hiroshima Univ., Ser. A: Math. Phys. Chem.*, 17 (1953) 257.
- 7 W.H. MacIntire and T.B. Stansel, *Ind. Eng. Chem.*, 45 (1953) 1548.
- 8 D. Janjic, E. Briner and H. Paillard, *Helv. Chim. Acta*, 38 (1955) 349.
- 9 J. Wuhrer, G. Radermacher and W. Lahr, *Tonind, Z. Keram. Rundsch.*, 80 (1956) 100.
- 10 F. Paulik, J. Paulik and L. Erdey, *Talanta*, 13 (1966) 1405.
- 11 J. Paulik and F. Paulik, *Thermochim. Acta*, 3 (1971) 13.
- 12 F. Paulik and J. Paulik, *J. Therm. Anal.*, 5 (1973) 253.
- 13 F. Paulik and J. Paulik, *Thermochim. Acta*, 4 (1972) 189.
- 14 K. Wieczorek-Ciurowa, F. Paulik and J. Paulik, *Thermochim. Acta*, in press.
- 15 F. Paulik and J. Paulik, in I. Buzás (Ed.), *Thermal Analysis, Proc. 4th Int. Conf. Therm. Anal.*, Budapest, July 1974, Akadémiai Kiadó, Budapest, Hungary, Vol. 3, 1974, p. 779.
- 16 Z.G. Szabó, M. Gánor, E. Kőrös, L. Poppl, J. Wajand and N. Varga, in I. Buzás (Ed.), *Thermal Analysis. Proc. 4th ICTA Conf.*, Budapest, 1974, Akadémiai Kiadó, Budapest, Hungary, Vol. 2, 1975, p. 569.